



Sahara Series Automatic Bilge Pumps

4505 / 4507 / 4511 Installation Instructions

SAVE THESE INSTRUCTIONS

Form Number 69370 Rev C

03-08

This product carries the standard Attwood three-year warranty.

See www.attwoodmarine.com or Product Catalog for details.

CAUTION:

Read all instructions carefully before installing and using this product.

This pump is sealed and, therefore, submersible. However, the electrical wire connections must not be submerged. For extra protection, coat the butt joints and adjacent wire ends liberally with liquid electrical tape such as MDR® or Starbrite®.

Specifications

Part Num.	Model	Amp Fuse	ABYC Specifications 13.6-volts DC (GPH=Gallons Per Hour)			ISO Specifications 12.0-volts DC (LPH=Liters Per Hour)			Max Head (ft. @ 13.6v/ kPa @ 12v)
			Head 0 ft.	Head 3.3 ft.	Head 6.7 ft.	Head 10kPa	Head 20kPa	Head 20kPa	
4505	S500	2.0	500/1.5	350/1.4	200/1.4	1136/1.2	598/1.2	9/24	
4507	S750	5.0	750/3.0	625/2.8	450/2.8	1817/2.5	1306/2.5	16/36	
4511	S1100	6.0	1100/4.0	970/3.8	750/3.8	3104/3.3	2328/3.3	11'7"/28	

WARNING: To prevent injury, always disconnect the power source when installing or servicing any electrical product.

DO NOT use pump to remove gasoline, oil or other flammable liquids.

Always use the fuse amperage rating specified for your pump model. Failure to do so could result in serious personal injury or fire hazards.

Attwood bilge pumps are designed to exhaust STANDING WATER ONLY. They are not intended to prevent rapid accumulation of on-board water due to rough weather, hull damage, and/or other unsafe navigational conditions.

REQUIRED MATERIALS

- Hose and thru-hull fittings, available separately from Attwood:
 - Sahara Model 4505 and 4507-**
 - 3/4" I.D. hose: Attwood No. 4199 (includes 2 clamps)
 - 3/4" I.D. thru-hull: No. 3873 (straight), No. 66541 or 66547 (stainless steel straight), No. 3877 (90°), or No. 3878 (double-end)
 - Sahara Model 4511-**
 - 1-1/8" I.D. hose: No. 11551 (clamps not included)
 - 1-1/8" I.D. thru-hull: No. 3874 (white), No. 3874A (black) or No. 66543, 66549 (stainless steel), or No. 3879 (90°)
- Two (2) hose clamps suitable for (3/4" or 1-1/8") hose.
- AUTO/OFF/MANUAL dash-mounted control switch (Attwood No. 7615A).
- In-line fuse connector (Attwood No. 14341) and appropriate size fuse.
- Three (3) stainless steel #6 x 1/2" self-tapping screws, round or pan head. Use a #32 drill bit for pilot holes.
- Four (4) wire butt-connectors for 16-gauge wire.
- Two (2) insulated spade terminal connectors for 16-gauge wire.
- Suitable means to make electrical connections waterproof.
- Cordless drill.
- Screwdriver.

OPTIONAL MATERIALS

- 1/2"-thick marine plywood block (slightly larger than pump base).
- Waterproof adhesive (epoxy, silicone adhesive, or fiberglass resin) to mount block.
- 16-gauge wire (brown and black).

PUMP MOUNTING INSTRUCTIONS

WARNING: Remove the pump mounting base (See Figure 3). Remove the foam block that supports the float during shipping. Failure to do this prevents the pump from starting when water is present.

- Make sure the hull thickness is at least 1/2" thick. If not, place a block of 1/2" marine plywood (slightly larger than pump base) in the lowest part of the bilge. Be sure that the pump cover can be removed for cleaning in this position. Glue the plywood to the hull with a waterproof adhesive (epoxy, silicone adhesive, or fiberglass resin). See Figure 1.

Figure 1

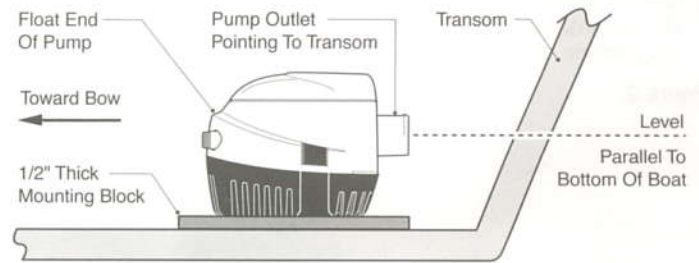

- Position the pump in the lowest part of the bilge on a flat, level surface (on the plywood block if it has been installed) with the outlet pointing toward the transom.
- Be sure outlet nozzle is level. If pointed upward or downward, an airlock may form in the pump. (See Figure 1.)
- The float end of the pump must be level with or above the pump end** (See Figure 1). This prevents the pump from running out of water while the float is still high enough to activate the pump.
- Mark location of the three (3) mounting holes with a pencil or scribe.

WARNING: When drilling holes do not drill through the hull!

- Carefully drill two 1/8" diameter pilot holes in marked area and drive a screw in each hole.
- Slide hose clamps (one to clamp hose to the pump, the other for the thru-hull connector) over end of the hose. Force hose over the discharge nozzle of the pump. Install clamp.
- Route hose on an upward incline to the thru-hull connector. Avoid dips in hose that can trap water and airlock the pump. Avoid putting excess tension on hose, which can damage the pump outlet.
- Force the hose over the thru-hull barbs and clamp into place.

THRU-HULL CONNECTOR INSTRUCTIONS

If no thru-hull connector exists, choose a location for the fitting.

- Position thru-hull fittings at least 12" above the water line to prevent water from coming back into the hull. On sailboats, mount the thru-hull high enough on the center of the transom to be above the water line at all times.
- Place fitting, if possible, on the same side as the steering wheel so the driver can see discharge of water when the pump is working properly.
- Drill hole to match outside diameter of the thru-hull connector thread.
- Place a small bead of suitable marine sealant around inside of the thru-hull connector flange.

⚠ WARNING: Do not allow sealants containing acetic acid (smells like vinegar) such as silicone rubber sealant to contact the plastic pump housing or thru-hull connector. Such sealants can attack the plastic, causing the pump housing to crack, resulting in pump failure.

5. Insert thru-hull connector through the hole and tighten to hold the thru-hull connector firmly in place. **CAUTION: Do not overtighten the nut.**

WIRING INSTRUCTIONS

⚠ WARNING: Be certain that power source is 12-volt D.C. Higher voltage will damage the pump.

1. Using the full length of wire provided (and additional wire if necessary), connect wires to the pump as shown in the diagram. (See Figure 2.)

Figure 2

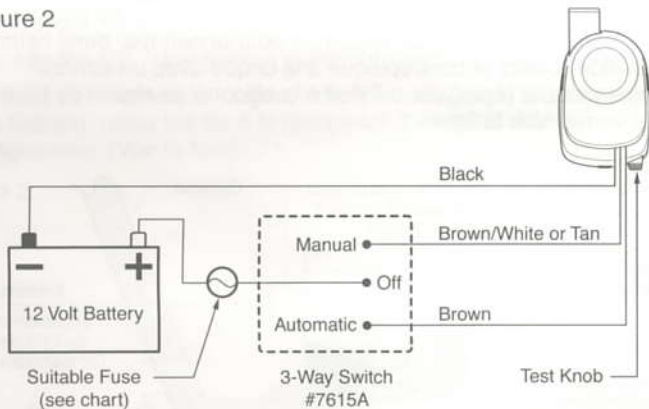

2. Route wires out of the way and secure them to the bulkhead to avoid pulling.
3. Using butt connectors sized for 16-gauge wire, splice fuse holder into positive lead (brown) between the battery and switch. Position fuse holder in a location that is easily accessible for changing fuses.

IMPORTANT: Use fuses of the proper amperage (See Specification Chart at top of sheet).

⚠ WARNING: FAILURE TO PROPERLY FUSE AND MAKE THE APPROPRIATE WATERPROOF CONNECTIONS WILL VOID THE PRODUCT WARRANTY.

4. Install a Three-Way Switch (Attwood No. 7615A) that allows for automatic or manual switching modes.
5. Turn the pump on and twist the Test Knob clockwise to check operation. Feed water into the pump. If output appears to be too low, check the wire connections. Reversed connections result in opposite impeller rotation that drastically reduces capacity and can cause premature pump failure.

CARE AND MAINTENANCE

Occasionally check your pump to be certain debris is not jamming the impeller and/or float within the housing. Use the test knob by rotating in a clockwise direction. Careful attention will guarantee outstanding pump performance.

To clean the water chamber, remove pump housing from the mounting base by pressing in tabs on sides. Lift the pump housing away. (See Figure 3.)

To clean the impeller, remove the impeller guard screw and lift the impeller guard.

Figure 3

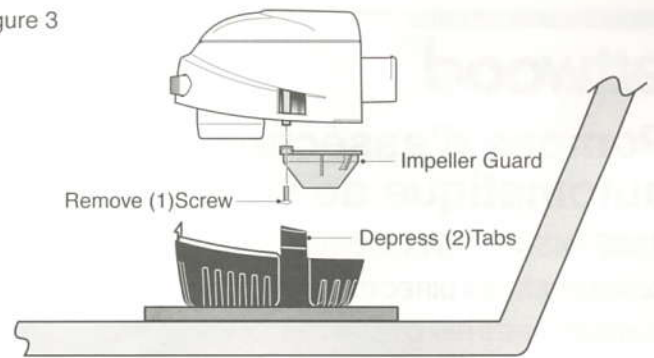

Remove all debris that has accumulated in pump chamber and around the impeller. Ensure that all debris is removed from strainer slots around the pump base.

Inspect the impeller to ensure that it is firmly attached to shaft and is not cracked or broken.

Replace impeller guard, screw, and pump housing on base. Be certain that all tabs are fully engaged.

Periodically check the electrical connections to ensure they are water-resistant and mounted high and dry.

Do not use household cleaners on the pump because many of them may damage the pump materials.

ATTWOOD LIMITED WARRANTY

ATTWOOD CORPORATION, 1016 North Monroe, Lowell, Michigan 49331 ("Attwood") warrants to the original consumer purchaser that Attwood brand products will be free from defects in materials and workmanship under normal use and service for three years from the date of original consumer purchase. This warranty does not extend to any batteries or fuses used with the product. This limited warranty is not applicable if the product has been damaged by accident, improper installation, unreasonable or improper use, lack of proper maintenance, unauthorized repairs or modifications, normal wear and tear, or other causes not arising out of defects in materials or workmanship. Attwood products are warranted for use on pleasure boats. Any other use — including but not limited to commercial, racing, or non-marine use — are not covered under this warranty. Attwood's obligation under this warranty is limited to repair of the product at Attwood's plant or replacement of the products at Attwood's option without expense to the original consumer purchaser. Any expenses involved in the removal, reinstallation or transportation of the product are not covered by this warranty. The product must be returned to Attwood's plant at the address above, postage prepaid, and insured with proof of original purchase including date. If Attwood is unable to replace the product and repair is not commercially practical or cannot be timely made, or if the original consumer purchaser is willing to accept a refund in lieu of repair or replacement, Attwood may refund the purchase price, less an amount for depreciation. The acceptance by Attwood of any product returned or any refund provided by Attwood shall not be deemed an admission that the product is defective or in violation of any warranty. Products that are replaced or for which a refund is issued become the property of Attwood.

THIS WARRANTY IS ATTWOOD'S ONLY EXPRESS WARRANTY OF THIS PRODUCT. NO IMPLIED WARRANTY SHALL EXTEND BEYOND THREE (3) YEARS FROM THE DATE OF ORIGINAL CONSUMER PURCHASE. ATTWOOD SHALL NOT BE LIABLE FOR ANY DAMAGES, FOR LOSS OF USE OF THIS PRODUCT, NOR FOR ANY OTHER INCIDENTAL OR CONSEQUENTIAL DAMAGES, COSTS OR EXPENSES.

Some states do not allow limitations on how long an implied warranty lasts or the exclusion or limitation of incidental or consequential damages, so the above limitations and exclusions may not apply to you. This warranty gives you specific legal rights, and you may have other rights which vary from state to state.